



DIALOG® 20 Wireless Microphone System

Quick Start Guide

Table of Contents

Setting up the system	3
Box Contents	3
Accessories	3
Set Up	3 - 4
Syncing the Transmitters with the Receiver	4
DIALOG 20 Software	5
Editing the Transmitter Parameters	5
Opening the Channel Edit Window	5
Software Functions	6 - 7
Receiver Front Panel	8
Receiver Back Panel	8
Receiver Module Panel	9
Reading Transmitter LED	9
Transmitters	10
Handheld	10
Beltpack	10
Tabletop Boundary	11
Podium Gooseneck Stem	11
Podium Gooseneck	12
Using DIALOG 20, CONVERGE PRO 2 DSP And Beamforming Mic Array	13
DIALOG 20 AND CONVERGE Pro 2 DSP	13
DIALOG 20, CONVERGE Pro 2 AND Beamforming Mic Array 2	13
Multiple DIALOG 20, CONVERGE Pro 2 and Beamforming Mic Array 2	13
DIALOG 20 AND 3 rd Party DSP	13
Suggested Mounting Options	14
Exposure and Compliance	15-16

Setting Up ClearOne DIALOG® 20 Wireless System:

Open the Cartons and Confirm the Contents.

DIALOG 20 Receiver:

- (Qty. 1) 2-Channel Receiver Base Unit with pre-installed rack ears.
- (Qty. 2) 2.4 GHz Dipole antennas (Plenum)
- (Qty. 1) USB Wall Adaptor (Universal Plug)
- (Qty. 1) USB (Micro) cable
- (Qty. 1) 12' (ft) RJ45M/RJ45M Cable
- (Qty. 1) Quick Start Guide

DIALOG 20 Charging Dock:

- (Qty. 1) Charging Dock Base Unit
- (Qty. 1) Power Cord

DIALOG 20 Podium Mic:

- (Qty. 1) Podium Mic Base Unit
- (Qty. 1) Battery Cassette
- (Qty. 4) Batteries
- (Qty. 1) Cardioid Mic Capsule
- (Qty. 1) Wind Screen

DIALOG 20 Handheld Mic:

- (Qty. 1) Handheld Base Unit
- (Qty. 2) Batteries
- (Qty. 1) Mic Clip

DIALOG 20 Boundary Mic:

- (Qty. 1) Boundary Mic Base Unit
- (Qty. 2) Batteries

DIALOG 20 Belt Pack:

- (Qty. 1) Beltpack Base Unit
- (Qty. 2) Batteries
- (Qty. 1) Beltpack Antenna

Available Accessories:

DIALOG 20 Antenna Extension Kits:

- 10' (ft) (RG58, Plenum Rated Cables)
- 25' (ft) (RG8, Plenum Rated Cables)

Other Accessories:

- XLR to Phoenix Adaptors
- PoE Power Supply Kit
- CAT 6 Cables
- Rack Shelf

Set up the System:

- Setting up the Docking Station:** ClearOne transmitters are shipped with rechargeable batteries. Plug in the charging dock, put the batteries in the transmitters, then place the transmitters in the dock while you set up the rest of the system.

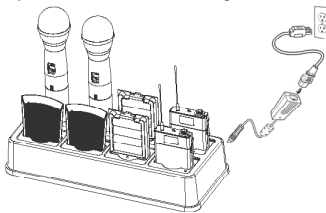

For new NiMH batteries, it is necessary to cycle them three to five times before they reach peak performance.

- Mount the Receiver:**

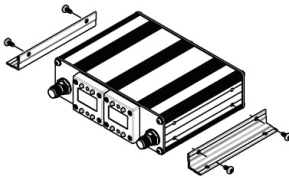

- Rack Mount:** Using the optional Rack Shelf accessory, mount the Rack Shelf in the AV rack and secure the receiver to Rack Shelf using the pre-installed rack ears.
- Wall Mount:** Secure the receiver to wall using the pre-installed rack ears.
- Ceiling Mount:** Secure the receiver to ceiling using the pre-installed rack ears.

- Mount Dipole Antennas:** Mount the Dipole Antennas on the receiver. Position the antennas at approximately 340° and 20° degrees. Keep line of sight between the transmitter and receiver antennas.

Antennas can be extended for better reception. Refer to the DIALOG 20 Antenna Installation Guide for detailed instructions on how to use extension cables and mounts.



Antennas must be securely installed by adding non-conductive adhesive to the threads of the Female TNC Connectors on the receiver.

- Power the Receiver:** Power the receiver using one of three sources:
 - USB** (USB Micro to USB with A/C Adaptor)
 - P-Link** (From CONVERGE PRO 2 or, Beamforming Mic Array 2)
 - PoE** (Power over Ethernet 802.3af Mode B, Midspan).

If P-Link/PoE and the USB cable are connected at the same time, one will act as backup power supply.

- Antenna Extension Cables:** Antenna extension cables are available in 10' (ft) (3.05m) and 25' (ft) (7.62m).

Refer to the DIALOG 20 Antenna Installation Guide for detailed instructions on how to use extension cables and mounts. Antennas must be securely installed by using a non-conductive adhesive on the TNC connection.

- Connect the analog outputs to the mixer:** The system is shipped with XLR connectors. You can also add optional XLR to Phoenix Adaptor as needed. The default output level is set to 0 dBu.

Setting Up ClearOne DIALOG® 20 Wireless System (Continued):

7. **Download and Install the Software:** Using a PC running Windows 7 or later (32 or 64 bit), with internet connection, download and install the DIALOG 20 Software. Go to:
www.ClearOne.com / Resources / Resource Library / Professional Microphones / ClearOne Wireless Microphones / Software Downloads.
Refer to the DIALOG 20 Software User Manual for detailed instructions on how to use the software.
8. **Update Receiver Firmware:**
 - a. Connect the receiver to a PC using Type A to Micro USB cable (You must have administrator rights).
 - b. Open the DIALOG 20 Software and Click “Update System”.
 - c. Click the “Download Button”.
 - d. You will see the Firmware and Software Version Information Page (DIALOG 20 information is at the bottom of the page).
 - e. Check the boxes that correspond to the firmware updates needed (marked in red).
 - f. Click “Download Selected” button to start the download.
 - g. The “On Hard Drive” status bar will turn green when the download has completed.
 - h. Click the “Cancel” button to return to the “Update Wizard” screen.
 - i. Click “Update a Receiver” to open the “Receiver Version Information” screen.
 - j. Click the “Update Receiver” button to open the “Upgrade Master Hub” screen.
 - k. Click the “Start” button and wait for “Updating is Done” confirmation.
 - l. Repeat the process for the Slave Hub and FPGA (If needed).
 - m. Confirm the current software is installed. The status bar will be green.
 - n. Close the window to return to the “Update Wizard” screen.
 - o. To update a transmitter, click the “Update A Transmitter” button and follow the screen prompts.
9. **Update Transmitter Firmware:**
 - a. Connect the receiver to a PC using Type A to Micro USB cable (You must have administrator rights).
 - b. Open the DIALOG 20 Software and Click “Update System” to open the “Update Wizard”.
 - c. Click the “Update A Transmitter” button and follow the screen prompts.
10. **Open the Software and Connect to the System in Online Mode.**
11. **Load / Save ClearOne Default Presets.**
12. **Perform an RF Scan** (Note the open channels. These will be used in the next step.).
13. **Edit the TX Parameters** (Set RF Channels, Preamp Gain, etc.).
14. **Edit Additional Settings** (Tour Mode, Redundancy, Ethernet, etc.).
15. **Sync the Transmitters:** (See below).

Syncing DIALOG® 20 Transmitters with Receiver:

How to sync transmitters with the receiver:

1. Power on the receiver.
2. Simultaneously press the two buttons on the bottom of the corresponding receiver module. “SYNCING” shows on the receiver OLED.
 - a. To sync a Boundary Mic or Podium Mic:
Press and hold the “Mute” button and then power on the transmitter.
 - b. To sync a Handheld or Beltpack:
Press and hold the “S” button and then power on the transmitter.
3. Repeat the procedure if the receiver display shows “SYNC FAIL”.
4. Check audio.

Both the transmitter and receiver OLED will read “SYNC PASS” when the sync is successful.

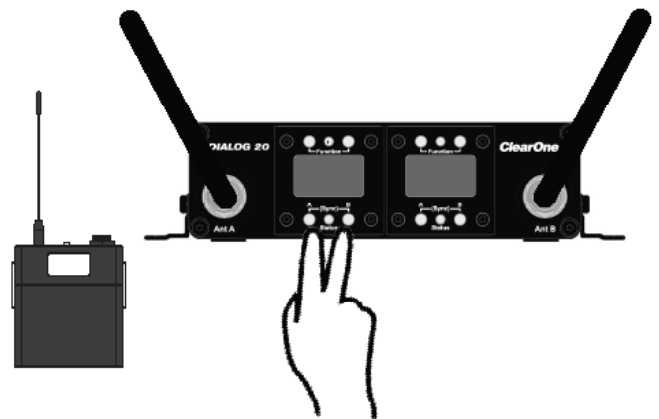

The transmitter and receiver are assigned a new, random AES 128-bit encryption key every time they are synced.

Using the ClearOne DIALOG® 20 Software:

Editing Transmitter Parameters:

The easiest and most intuitive way to set the parameters of ClearOne transmitters and receivers is with ClearOne DIALOG 20 Software. Download the software from www.ClearOne.com. Load the Software onto a computer running Windows 7 or above (32 or 64-bit). Connect to the receiver via the USB connection located on the back panel. There is a micro-USB to USB cable provided with the receiver. Use this cable to power the receiver and to connect it with a computer to configure the system.

Open The Channel Edit Window:

1. Open ClearOne Remote and select ONLINE.
2. The [Click to Edit] function opens the edit window of the channel you wish to edit.
3. Select the functions you want to edit and enter the parameter (The various functions are described below). Click [OK] to save the changes and close the Channel Edit window.
4. If the mic was previously synced, the settings will be applied automatically. If the mic has not previously been synced, you will notice that the [Need to Sync] alert is lit. This indicates that one or more parameters are in queue in the receiver ready to be downloaded and implemented with the next transmitter Sync of the channel.

Refer to the Software User Manual for detailed instructions on how to use the software and all of it's features.

A) Click to Edit the channel's parameters.

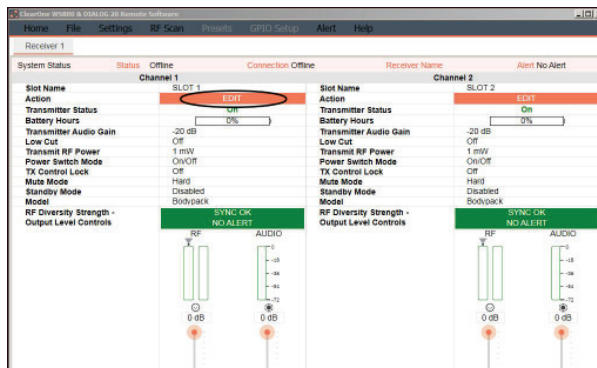

B) Select new parameter values, click "Apply and Close".

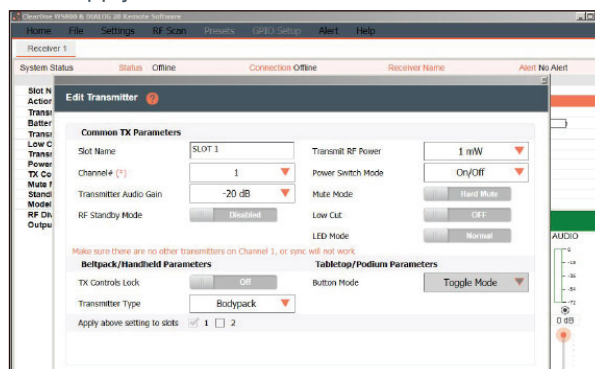

C) The Transmitter will apply the new settings automatically. You will not have to re-sync the transmitter.

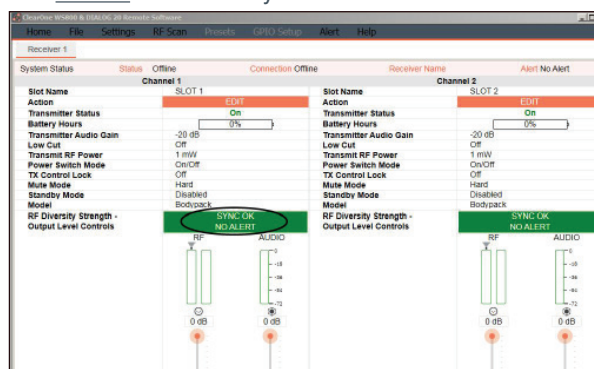

ClearOne DIALOG 20 Software provides the following functions:

- **File:** The file menu allows the current receiver settings to be saved to a file on your computer or for a previously saved file on your computer to be recalled to the receiver.
- **Settings:**
 - A. **Redundancy:** Audio redundancy mode allows two receiver slots and two transmitters to be used on one audio source. The audio is selected from the channel with the best audio signal and output on the odd numbered channel. For example, if receiver modules 1 and 2 are selected for redundancy, the audio output will be on channel 1. Redundancy is useful when audio transmission is critical.
 - B. **Receiver OLED Dimming:** Set the Receiver OLED Display Mode and timer value. Default = Bright when transmitter is on and dims when transmitter is off. Times out after 1 minute.
 - C. **Print Current Settings:** Opens print dialog box.
 - D. **Set Receiver Name:** label each receiver with a unique name using up to 26 characters.
 - E. **Channel Mode:** Choose between Wide Band and Narrow Band. Default = Wide Band.

Wide Band 8ch mode: Uses 4 frequencies spaced widely across the RF band.

Pros: Can cause less interference to WiFi devices that are occupying the same frequencies.

Cons: Does not always take advantage of white spaces between WiFi devices.

Narrow Band 16ch mode: Uses 4 frequencies spaced closely together in the RF band.

Pros: Can allow the use of more narrow white spaces between WiFi devices.

Cons: Can cause more interference to WiFi devices that are occupying the same frequencies.

Wide Band Mode:



Narrow Band Mode:



- **RF Scan - RF Plot:** Shows the RF strength of each antenna in a ClearOne system and shows if there is outside interference.
- **Presets:** Saves settings to receiver memory or recalls settings from receiver memory. Choose “Load SYSDEFAULT” for the factory default settings.
- **GPIO Setup:** This function can mute the microphone based on a GPIO input. Also, it can tell a downstream DSP device if a microphone channel is muted based on a GPIO output.

GPIO Setup:

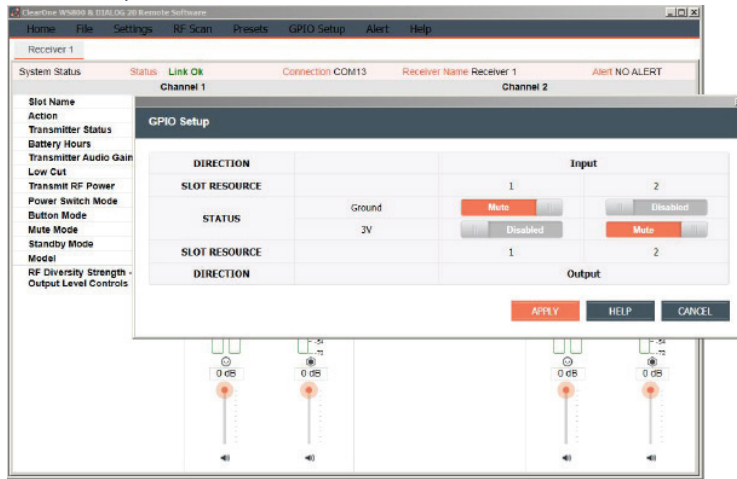

The Mute Mode is setup in the Edit Transmitter Window and it is set to either Hard Mute or Logic Mute. In Hard Mute, when either the microphone mute button is pressed or, if a GPIO input tells the microphone channel to mute, then the actual hard analog output of the receiver is muted. In logic Mute, only the GPIO output pin is driven to tell a downstream DSP that the channel is muted.

The LED Mode is setup in the Edit Transmitter Window

The 2-way LED control works as follows:

- In normal mode, the GPIO input on the back panel of the receiver is ignored and the muted LED on the microphone follows the mute button on the microphone.
- In 2-way LED mode, the GPIO input on the back panel of the receiver controls the LED on the microphone.
- The logic mute GPIO output for downstream DSP muting is independent from the LED muting.

LED Mode:

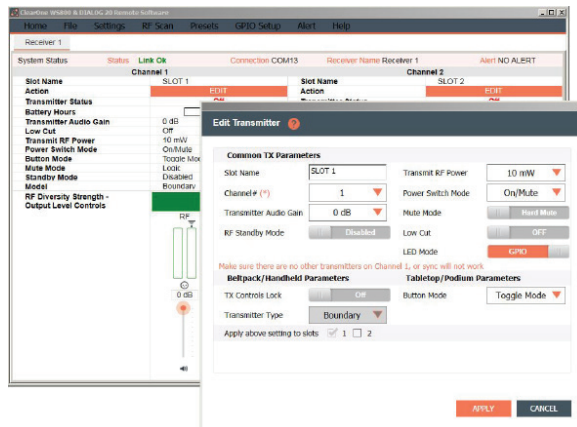

Mute Mode:

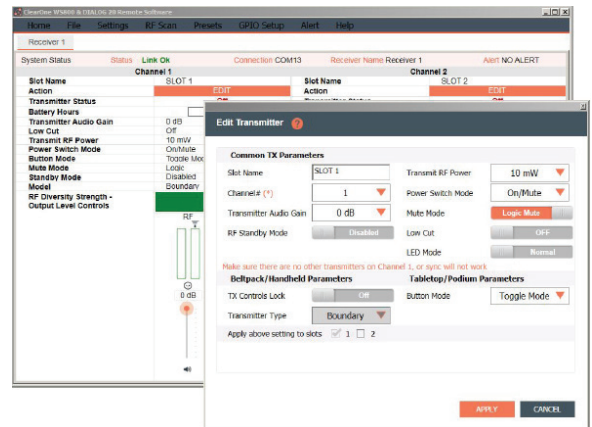

- **Alert:** Gives the user the ability to set alert conditions, such as, low battery, battery runtime hours, low RF signal, and Transmitter turned off.
- **Help:** The “About” tab contains the system information.

Default Transmitter Preamp Gain Settings:

Transmitter + Last 4 digits of serial Number	Default Transmitter Preamp Gain
BLT XXXX	+10 dB
HH XXXX	H18 = 0dB / H13 & H15 = +20dB
PDM XXXX	+10dB
BDM XXXX	+20dB

Key:

- BLT = Beltpack
- HH = Handheld Mic
- PDM = Gooseneck Podium Mic
- BDM = Tabletop Boundary Mic

DIALOG® 20 Receiver Front Panel:

ClearOne DIALOG 20 receiver main-frames hold two, independent, 24-bit digital audio receiver modules. Each module shares the main-frame's two antennas for full-diversity. Two receiver main-frames can be daisy-chained together allowing up to 4 channels or up to 6 channels when connected with CONVERGE PRO 2 DSP mixer. Main-frames can be connected via P-Link as a peripheral link for CONVERGE PRO 2 and Beamforming Mic Array 2. Power is supplied by Micro-USB, P-Link or, Power over Ethernet (PoE). Main-frames have a USB connection for serial monitor and control.

When more than one DIALOG 20 Receiver is used in the same RF space, provided enough RF spectrum is available without interference, they must be P-Linked together to avoid additional interference or dropouts. Connect the CAT5e / CAT6 Cable from the P-Link out of the first Receiver to the P-Link in of the second Receiver.

When using a CONVERGE Pro 2 Mixer, a maximum of 3 DIALOG 20 Receivers can be daisy-chained together (provided there is enough RF spectrum available for 6 channels).

Front:

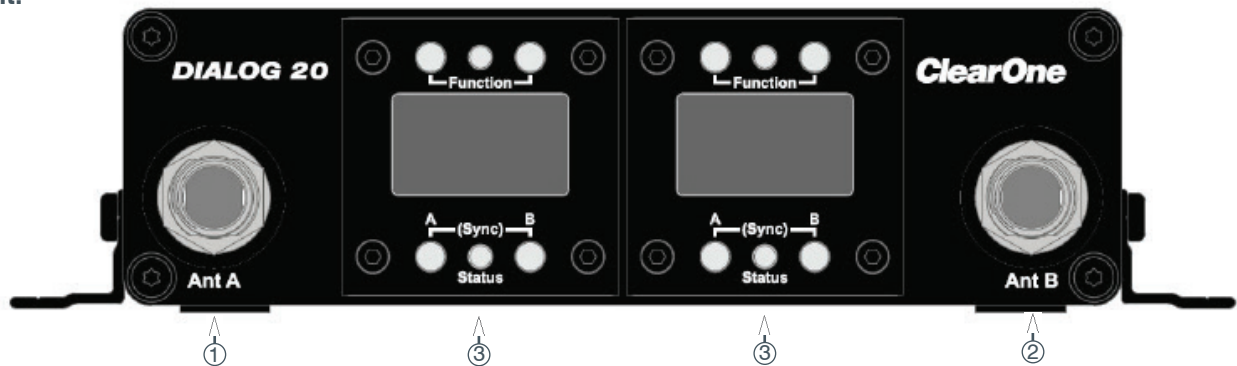

1. Antenna "A" TNC Connector.
2. Antenna "B" TNC Connector.
3. Receiver Front Panel (See details next page).

DIALOG® 20 Receiver Back Panel:

Back:

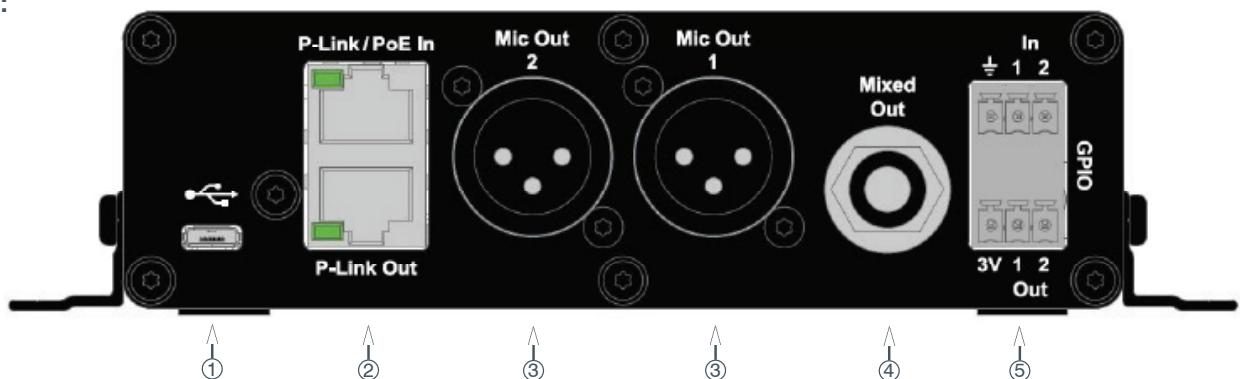

1. **Micro USB:** USB power or connect to PC (Micro USB power Cord wall adaptor with local plug configuration Included).
2. **P-Link / POE (Power Over Ethernet):** Peripheral link for CONVERGE PRO 2 and Beamforming Mic Array 2. Multiple receiver-frames can be daisy-chained together to form a network.
3. **Audio Output Jacks:** (2) independent, balanced XLR outputs.
4. **Mixed Out:** Balanced 1/4 inch TRS mixed line out for recorders, powered speakers.
Mixed out is not designed to be used with headphones.
5. **GPIO:** Allows muting of a microphone channel on GPIO input and sends microphone mute status on GPIO output.

DIALOG® 20 Receiver Module Panel:

Module Panel:

Module Panels are designed for quick and easy field replacement for added redundancy.

① & ② Pressed at the same time: Receives SYNC signal from transmitter (see pg. 3).

③ Status LED:

- **Green** The channel is ON and un-muted.
- **Red** The channel is OFF.
- **Flashing Red** Encryption key mismatch or, two transmitters are synced to the same Receiver.
Solution: Re-sync receiver with transmitter.
- **Amber** The receiver is muted or GPIO is triggered.

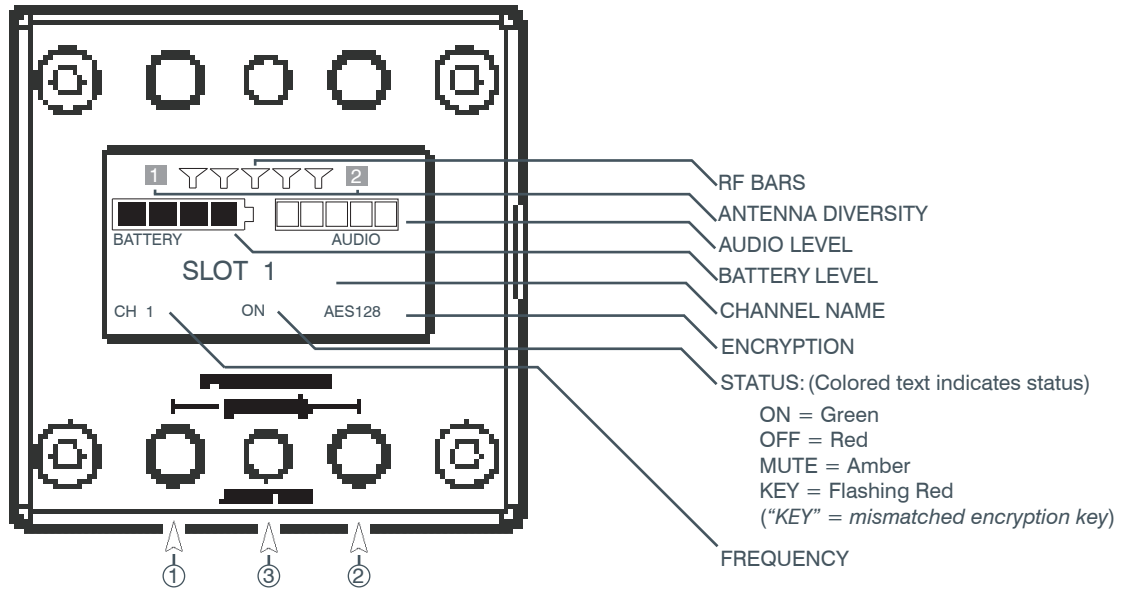

Reading the Transmitter LED:

How to read the LED:

The Gooseneck or Boundary Mic is in use:

Battery Power:

- RED = AUDIO MUTE
- GREEN = AUDIO PASSES
- BLINKING GREEN = SYNC SUCCESSFUL
- BLINKING RED SLOW = BATTERY IS LOW

USB Charging (Power Switch On):

- GREEN = AUDIO UNMUTED
- RED = AUDIO MUTED
- GREEN FLASHING = SYNCING

USB Charging (Power Switch Off):

- RED = NOT YET CHARGING
- AMBER = CHARGING
- GREEN = CHARGED

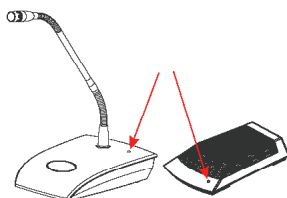

The Gooseneck Battery Cassette is in the Docking Station:

- RED = CHARGING
- OFF = FINISHED CHARGING
- BLINKING RED = CHARGING ERROR
(RE-SEAT TRANSMITTER / CHECK BATTERIES)

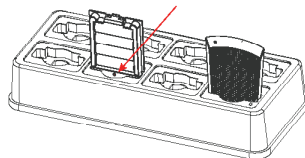

The Boundary Mic is in the Docking Station:

- RED change to AMBER = CHARGING
- GREEN = FINISHED CHARGING
- GREEN & RED BLINKING = CHARGING ERROR
(RE-SEAT TRANSMITTER / CHECK BATTERIES)

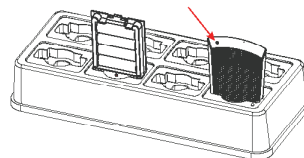

The Hand-held mic or Belt Pack is in the Docking Station:

- The OLED shows the battery status.

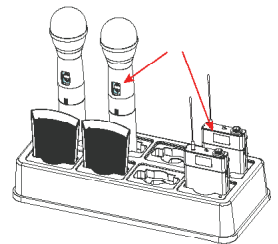

All transmitters placed in the Charging Dock will "RF MUTE".

DIALOG® 20 Transmitters:

DIALOG 20 HANDHELD MICROPHONE:

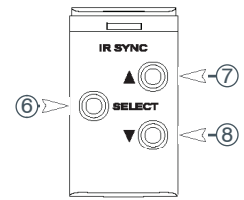
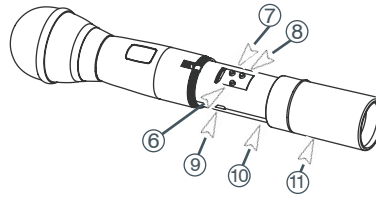
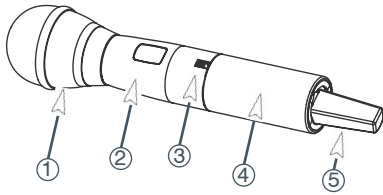

1. **Heads:** Three (3) choices of microphone capsules are available:
 H-13 (Dynamic, Super Cardioid for performance)
 H-15 (Dynamic, Hyper Cardioid for performance)
 H-18 (Condenser Cardioid for conferences)
 Condenser heads are more “transparent” and do not require the microphone to be held as close to the mouth.
 Dynamic heads are less prone to audio feedback in sound reinforcement environment.
2. **Display:** OLED display is used to program and display the current status of the transmitter functions.
3. **Switch:** User programmable to toggle on/off, on/mute/ or on/on.
4. **Battery and Control Cover:** Unscrew counter-clockwise and gently slide open.
5. **Antenna Cover:** Do not hold the antenna cover. Your hand will shield the RF signal and cause poor performance.
6. **Select button:** Select a function. The first press activates the Power Setting function (1 - 10 mW). Press Select again to program the external switch (on/off, on/on, on/mute). Press again to set the level (-20 dB to +30 dB). Press Select a fourth time to set the Low Cut Filter (off / 75Hz). To prevent accidental parameter changes, the select button can be locked using the Remote Software.
7. **Parameter Up:** Press this button to increase the value of the selected function.
8. **Parameter Down:** Press this button to decrease the value for the selected function.
9. **USB Port:** Plug a micro USB cable into the USB port to charge the batteries or upgrade the firmware.
10. **Batteries:** (not shown) Two AA, NiMH batteries for up to 12 hours continuous usage per charge. AA NiMH, 2500-mAhr or greater is recommended.
11. **Battery Door:** Open position.

DIALOG 20 BELTPACK:

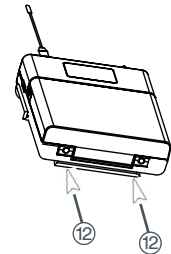
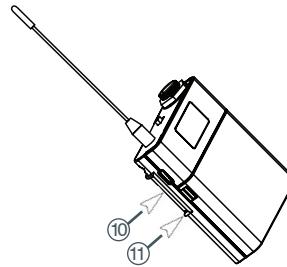
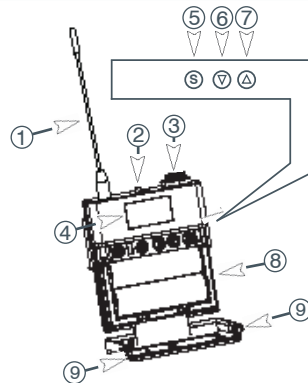

1. **Antenna:** Antennas are field replaceable to improve reliability and redundancy.
2. **Programmable Switch:** Toggle on/off, on/mute/ or on/on.
3. **Microphone Connector:** TA4 mini XLR style: ClearOne offers a full range of lavalier and headset mics for optimal performance of your DIALOG 20 transmitter. Works with both snap in and screw-in microphones.
4. **Display:** OLED display is used to program and display the current status of the transmitter functions.
5. **Select:** Select a function. The first press activates the Power Setting function (1 - 10 mW). Press Select again to program the external switch (on/off, on/on, on/mute). Press again to set the level (-20 dB to +30 dB). Press Select a fourth time to set the Low Cut Filter (off / 75Hz). To prevent accidental parameter changes, the select button can be locked using the Remote Software.
6. **Parameter Down:** Press this button to decrease the value for the selected function.
7. **Parameter Up:** Press this button to increase the value of the selected function.
8. **Batteries:** Two AA, NiMH batteries for up to 12 hours continuous usage per charge. AA NiMH, 2500-mAhr or greater is recommended.
9. **Battery Door Locks:** To open, press both at the same time and lift the door open. To close, snap the door closed.
10. **USB Port:** Plug a micro USB cable into the USB port to charge the batteries or upgrade the firmware.
11. **Belt-Clip:** Spring-loaded clip for attaching the transmitter to a belt or similar object. Spring pressure presses the clip into two holes in the transmitter body. Pull them out to remove or reverse the clip. Exercise caution to prevent injury or scratching the case.
12. **Contacts:** Charging contact points for the docking station.

DIALOG® 20 Transmitters:

DIALOG 20 TABLETOP BOUNDARY MICROPHONE:

The ClearOne DIALOG 20 Tabletop Boundary Microphone combines the professional audio specs and security of a wired mic with wireless convenience. Available in Omni or Cardioid polar pick-up patterns.

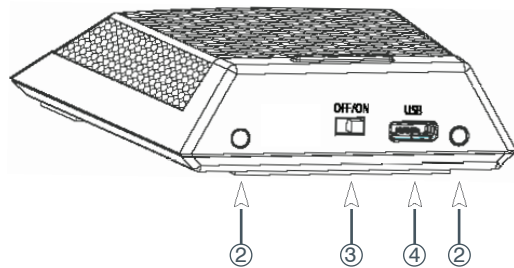
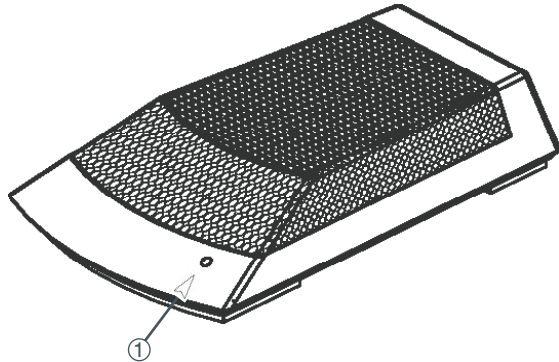

1. **Power LED:** (see Pg. 8 “Reading the Transmitter LED:”).

When the Boundary Mic is in use, the LED signals:

Red = audio mute.

Green = audio passes.

Blinking Red = battery low.

Blinking Green = sync successful.

2. **Contacts:** Contact points for the charging station.
3. **Power Switch:** On / Off.
4. **USB Port:** Doubles as the power supply / recharger connection and computer programming port. The transmitter operates normally under USB power, with dead or no batteries for permanent installations.
5. **Batteries:** Two AA, NiMH batteries for up to 12 hours continuous usage per charge. AA NiMH, 2500-mAhr or greater is recommended.

DIALOG 20 PODIUM GOOSENECK STEM :

ClearOne DIALOG 20 Gooseneck Podium Mic Stems are available in 6”, 12” and 18” lengths that are interchangeable. The Gooseneck Mic comes with a Cardioid polar pattern mic capsule.

1. **Two flexible stem sections for easy positioning.**
2. **A 4-pin XLR connector allows the exchange of Different length microphone stems.**

GOOSENECK MIC CAPSULE:

CARDIOID
pickup pattern



DIALOG® 20 Transmitters:

DIALOG 20 PODIUM GOOSENECK:

The ClearOne DIALOG 20 Podium Gooseneck Microphone combines the professional audio specs and security of a wired mic with wireless convenience. For use with battery power or permanently install the microphone using USB power.

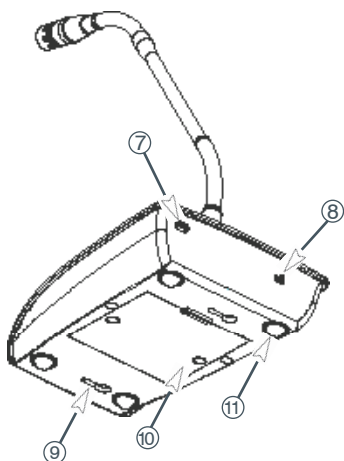
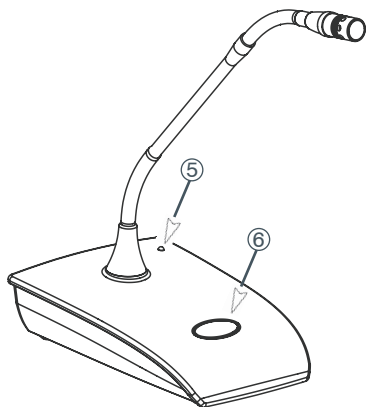
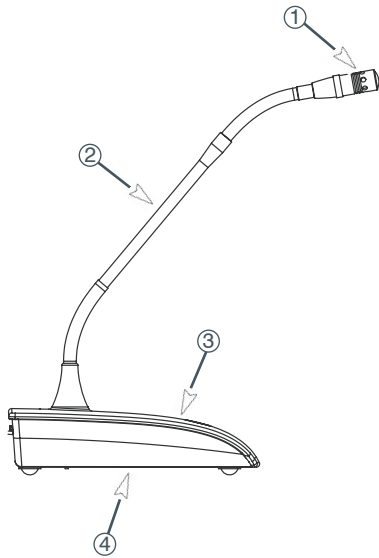

1. **ClearOne Mic Capsule:** Cardioid polar pattern.
2. **Goosenecks:** Two flexible sections to extend over a laptop or briefcase. Available in 6, 12, and, 18 inch lengths.
3. **Radio-transparent ABS Top:** Stylish design that hides and protects the antenna.
4. **Cast Metal Bottom:** Zinc base bottom adds stability and absorbs desk noise.
5. **Power LED:** (see Pg. 8 “Reading the Transmitter LED:”).
6. **Button Programming Options:**
 - 1) press to talk.
 - 2) press to mute.
 - 3) toggle on or off.
7. **USB Port:** Doubles as the USB recharger connection and computer programming port. The transmitter operates normally under USB power, with dead or no batteries for permanent installations.
8. **Power Switch Programming Options:**
 - 1) On / Off.
 - 2) On / Mute.
 - 3) On / On.
9. **Keyholes:** For permanent mounting.
10. **Battery Cassette:** Push tab to remove the battery cassette. Recharge the batteries by inserting the cassette into the ClearOne Charging Dock (See figure 1). The battery cassette holds four, off-the-shelf, AA, NiMH batteries for up to 24 hours continuous usage per charge.
11. **Rubber Feet:** Absorb desk noise and provide a stable, non-skid base.

(Figure 1)

Recharge the batteries by inserting the cassette into the ClearOne Charging Dock.

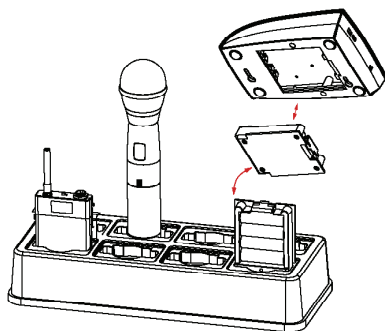

(Figure 2)

When the Gooseneck Mic is in use, the LED signals:

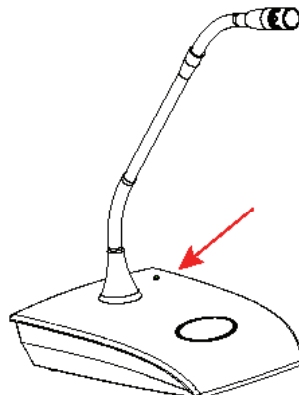

Mute
 io Passes
 | = Battery Low
 :EN = Sync Successful

Using DIALOG® 20 With CONVERGE Pro 2 And Beamforming Mic Array:

1. CONNECTING THE DIALOG 20 SYSTEM WITH THE CONVERGE Pro 2 DSP (native connection):

- P-Link directly to CONVERGE Pro 2
- One cable for audio, control and power.

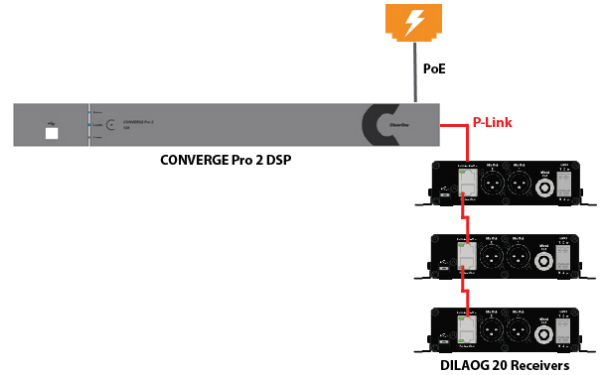

2. CONNECTING THE DIALOG 20 SYSTEM WITH THE CONVERGE Pro 2 AND Beamforming Mic Array 2 (native connection):

- Directly connects to CONVERGE Pro 2 and Beamforming Mic Array 2
- One cable for audio, control and power.

Application Example: Classrooms where Wireless Mic is needed for lecturer / presenter and Beamforming Mic is needed for students / participants.

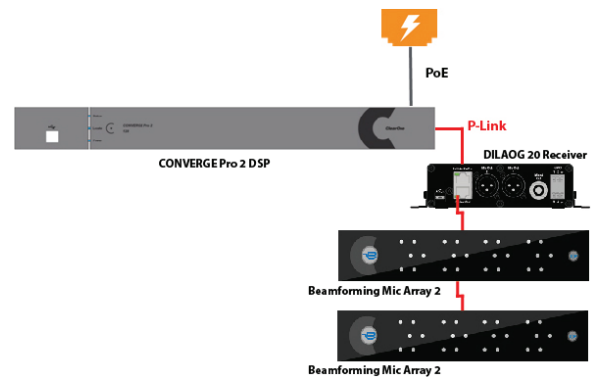

3. CONNECTING MULTIPLE DIALOG 20, CONVERGE Pro 2 AND Beamforming Mic Array 2 (native connection):

- Directly connects to CONVERGE Pro 2 and Beamforming Mic Array 2
- One cable for audio, control and power.
- Supports up to 6 peripherals.
- Up to 3 of each device type.
- PoE Power needed for every 3 P-Link devices.

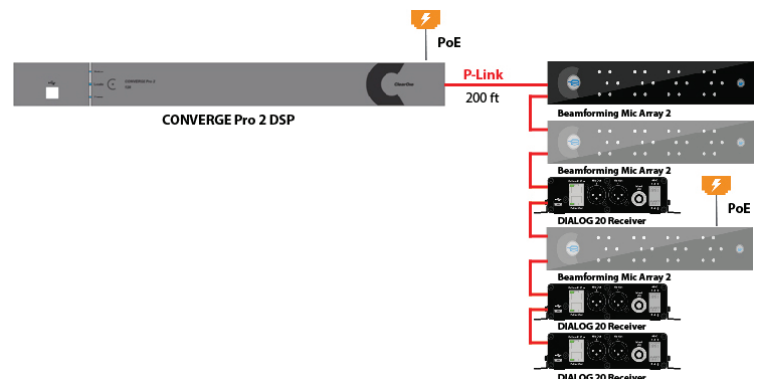

4. CONNECTING WITH ANY DSP MIXER:

- CONVERGE Pro 2 Mixer
- Other ClearOne DSP Mixers
- CONVERGE Pro
- INTERACT Pro
- INTERACT AT
- Any 3rd party DSP mixers (may require optional XLR to Phoenix adaptors)

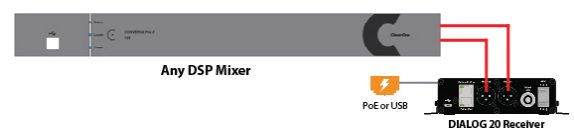

DIALOG® 20 Suggested Mounting Options:

Antenna Position
 AV Rack Mounted using optional
 10' Antenna Extension Kit

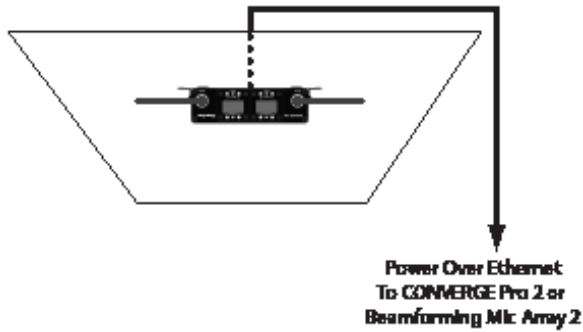
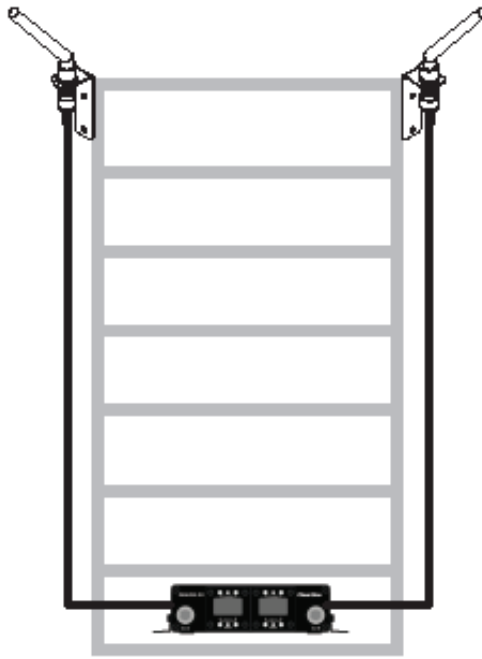

Power Over Ethernet
 To CONVERGE Pro 2 or
 Beamforming Mic Array 2

Plenum Rated Receiver Mounted on the
 Outside of Ceiling Tile with PoE to CONVERGE
 Pro 2 or Beamforming Mic Array 2

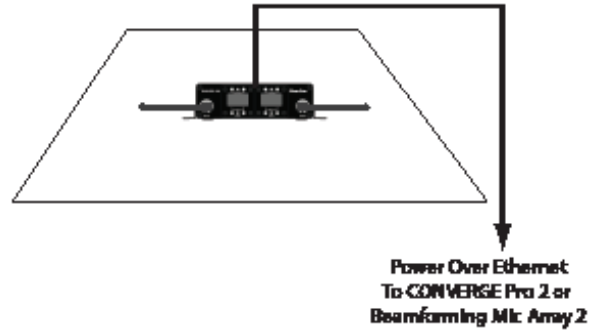

Power Over Ethernet
 To CONVERGE Pro 2 or
 Beamforming Mic Array 2

Plenum Rated Receiver Mounted on the
 inside of the Ceiling Tile, within the Crawl
 Space, with PoE to CONVERGE Pro 2 or
 Beamforming Mic Array 2

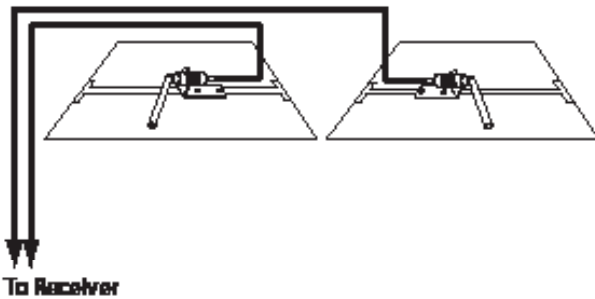

Plenum Rated Antennas Mounted on the
 inside of the Ceiling Tile, within the Crawl
 Space, using optional 25' Antenna Extension
 Kit and 3rd party "T-Bracket".

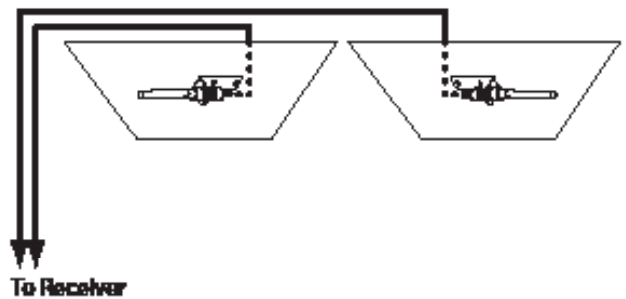

Plenum Rated Antennas Mounted on the
 Outside of Ceiling Tile using optional 25'
 Antenna Extension Kit

DIALOG® 20 Exposure and Compliance:

RF Exposure Information

The transmitters have been tested and have been shown to be compliant for localized specific absorption rate (SAR) for uncontrolled environment/general exposure limits specified in ANSI/IEEE Std. C95.1-1992 and have been tested in accordance with the measurement procedures specified in IEEE 1528-2003 and IEC 62209-2.

RF Compliance Information

The transmitters have been tested and have been shown to meet CE spectral bandwidth requirements at 1 mW and 10 mW output power.

This equipment may be capable of operating at some RF power levels not authorized in your region. Please contact your national authority to obtain information on RF power levels for wireless microphone products in your region.

This product meets the Essential Requirements of all relevant European directives and is eligible for CE marking.

Plenum Rated

The DIALOG 20 Receiver and antennas meet the UL 2043 plenum-rating standard and are certified to have adequate fire resistance and low smoke-emission characteristics to be mounted and operated in a building's environmental air spaces, such as above suspended ceilings in an office environment.

Certified under FCC Part 74 and FCC Part 15.
Certified by IC in Canada under RSS-123, RSS-102 and RSS-210.

Receiver:

Receiver
FCC ID: FBI-DIALOG20RX
IC: 1970A-DIALOG20RX

Transmitters:

BELTPACK
FCC ID: FBI-DIALOG20BLT
IC: 1970A-DIALOG20BLT

TABLETOP
FCC ID: FBI-DIALOG20BDM
IC: 1970A-DIALOG20BDM

GOOSENECK
FCC ID: FBI-DIALOG20PDM
IC: 1970A-DIALOG20PDM

HANDHELD
FCC ID: FBI-DIALOG20HH
IC: 1970A-DIALOG20HH

Modifications (FCC 15.21)

Warning:

Changes or modifications to this equipment not expressly approved by ClearOne may void the user's authority to operate this equipment according to your local radio regulatory authorities.

Clearone Wireless Receivers, Transmitters, and, Antennas are intended for indoor use only.

Applies to Beltpack (910-6004-00X):

Under Industry Canada regulations, this radio transmitter may only operate using an antenna of a type and maximum (or lesser) gain approved for the transmitter by Industry Canada.

To reduce potential radio interference to other users, the antenna type and its gain should be so chosen that the equivalent isotropically radiated power (e.i.r.p.) is not more than that necessary for successful communication.

This radio transmitter (910-6004-00X) has been approved by Industry Canada to operate with the antenna types listed below with the maximum permissible gain and required antenna impedance for each antenna type indicated. Antenna types not included in this list, having a gain greater than the maximum gain indicated for that type, are strictly prohibited for use with this device.

Monopole antenna, 0dbi gain, 50 ohm impedance.

Le présent émetteur radio (910-6004-00X) a été approuvé par Industrie Canada pour fonctionner avec les types d'antenne énumérés ci-dessous et ayant un gain admissible maximal et l'impédance requise pour chaque type d'antenne. Les types d'antenne non inclus dans cette liste, ou dont le gain est supérieur au gain maximal indiqué, sont strictement interdits pour l'exploitation de l'émetteur.

This device complies with Industry Canada licence-exempt RSS standard(s). Operation is subject to the following two conditions: (1) this device may not cause interference, and (2) this device must accept any interference, including interference that may cause undesired operation of the device.

France:

Le présent appareil est conforme aux CNR d'Industrie Canada applicables aux appareils radio exempts de licence.

L'exploitation est autorisée aux deux conditions suivantes : (1) l'appareil ne doit pas produire de brouillage, et (2) l'utilisateur de l'appareil doit accepter tout brouillage radioélectrique subi, même si le brouillage est susceptible d'en compromettre le fonctionnement.

DIALOG® 20 Exposure and Compliance:

Continued:

Electronic Code of Federal Regulations Title 47: Telecommunication
PART 15—RADIO FREQUENCY DEVICES Subpart A—General

§15.19 Labelling Requirements.

This device complies with part 15 of the FCC Rules. Operation is subject to the following two conditions: (1) This device may not cause harmful interference, and (2) this device must accept any interference received, including interference that may cause undesired operation.

Electronic Code of Federal Regulations
Title 47: Telecommunication
PART 15—RADIO FREQUENCY DEVICES
Subpart B—Unintentional Radiators

§15.105 Information to the user.

(a) For a Class A digital device or peripheral, the instructions furnished the user shall include the following or similar statement, placed in a prominent location in the text of the manual:

Note: This equipment has been tested and found to comply with the limits for a Class A digital device, pursuant to part 15 of the FCC Rules. These limits are designed to provide reasonable protection against harmful interference when the equipment is operated in a commercial environment. This equipment generates, uses, and can radiate radio frequency energy and, if not installed and used in accordance with the instruction manual, may cause harmful interference to radio communications. Operation of this equipment in a residential area is likely to cause harmful interference in which case the user will be required to correct the interference at his own expense.

(b) For a Class B digital device or peripheral, the instructions furnished the user shall include the following or similar statement, placed in a prominent location in the text of the manual:

Note: This equipment has been tested and found to comply with the limits for a Class B digital device, pursuant to part 15 of the FCC Rules. These limits are designed to provide reasonable protection against harmful interference in a residential installation. This equipment generates, uses and can radiate radio frequency energy and, if not installed and used in accordance with the instructions, may cause harmful interference to radio communications. However, there is no guarantee that interference will not occur in a particular installation. If this equipment does cause harmful interference to radio or television reception, which can be determined by turning the equipment off and on, the user is encouraged to try to correct the interference by one or more of the following measures:

- Reorient or relocate the receiving antenna.
- Increase the separation between the equipment and receiver.
- Connect the equipment into an outlet on a circuit different from that to which the receiver is connected.
- Consult the dealer or an experienced radio/TV technician for help.

(c) The provisions of paragraphs (a) and (b) of this section do not apply to digital devices exempted from the technical standards under the provisions of §15.103.

(d) For systems incorporating several digital devices, the statement shown in paragraph (a) or (b) of this section needs to be contained only in the instruction manual for the main control unit.

(e) In cases where the manual is provided only in a form other than paper, such as on a computer disk or over the Internet, the information required by this section may be included in the manual in that alternative form, provided the user can reasonably be expected to have the capability to access information in that form.



ClearOne®

Headquarters

5225 Wiley Post Way
Suite 500
Salt Lake City, UT.
84116

US & Canada

Tel: 801.975.7200
Toll Free: 800.945.7730
Fax: 801.303.5711

International

Tel: +1.801.975.7200
Email: global@clearone.com

Sales

Tel: 801.975.7200
Email: sales@clearone.com

Tech Support

Tel: 801.974.3760
Email: tech.support@clearone.com

Other product names may be registered trademarks of their respective owners who do not necessarily endorse ClearOne or ClearOne's products. All rights reserved.
Information in this document subject to change without notice. © 2017 ClearOne. QSG-0033-001 ClearOne_DIALOG_20_QuickStartGuide-V5.0 December, 2017

Antenna Design

Tel: 386.361.8134
Email: antenna.design@clearone.com